

Measumax

PRECISION DIGITAL HEIGHT GAUGE

36-2105

1. MAINTENANCE INSTRUCTIONS

- Before using the Measumax Digital height gauge, remove the protective coatings and clean the surfaces with dry and clean cloth (or soaked with cleaning oil).
- Operating Conditions: Temperature 5°-40°C
Relative Humidity: <80%
- Never apply voltage (e.g.: engraving with an electric pen) to any part of the Measumax Height Gauge. This may cause damaging to the circuitry.
- Set a preset starting point of measurement correctly (see 5. Operation) Do not press the "ON/ZERO" key, unless setting a new preset.
- The scribe edge is very sharp. Care should be taken at all time
- Prevent foreign objects from entering the gear at the back of the body.
- Please insure that fastening screw (7) and locking handle (6) have been loosened before the hand wheel (3) is turned. Failure to do this will cause damage to the gear and rack.

2. STRUCTURE

- | | |
|--|-----------------------------|
| 1. Base | 2. Battery cover |
| 3. Hand wheel, gear, gear-driven mechanism | 4. OFF key |
| 5. Pin of locking handle | 6. Locking handle |
| 7. Fastening screw | 8. Fine adjustment carriage |
| 9. Protective sticker | 10. Body |
| 11. Stopper | 12. LCD display |
| 13. mm/inch switch key | 14. Starting & Zero key |
| 15. Upper presetting key | 16. Lower presetting key |
| 17. Output port | 18. Slider |
| 19. Measuring Jaw Lock Clamp | 20. Measuring jaw |

3. KEY FUNCTIONS

- OFF – Switch off LCD Display
 ON/ZERO – Start LCD Display and Zero-setting
 Mm/Inch-Set mm/inch
 ADD+ - Add presetting value
 SUB – Subtract presetting value

4. OUTPUT PORT

Data can transferred to a printer via a special connecting cable. The interface works by synchronous serialization by 24 bit binary code. The datum is transferred twice at a cycle of 300ms. Transmitting time 0.5ms.
 Four wires (from left to right) Negative (-), Clock pulse (CP), Data (D) and Positive power (+)
 Pulse range of data: 0 Level <0.2V, Level 1 >1.3V.
 Clock pulse CP: 90KHz effective for high electric level.

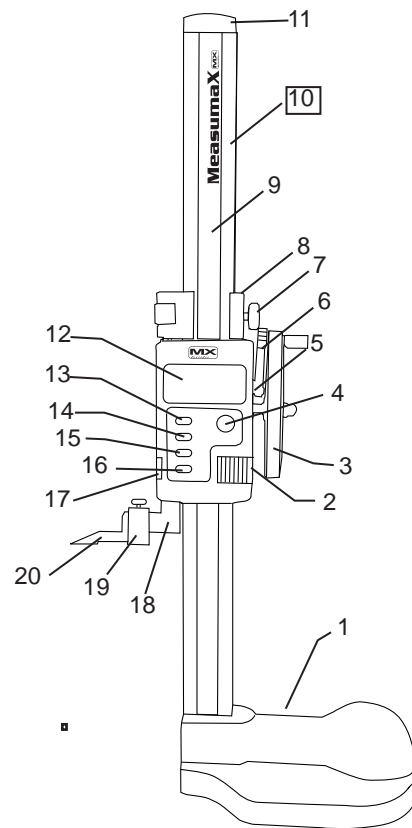

5. OPERATION

- Dry and clean the surface of the protective strip and clean the base and the measuring jaw. Fix the measuring jaw with the clamp [19] at the desired position.
- Clean the working platform and the base of the height gauge. Place the height gauge on the platform and loosen the locking screws [6&7] and move the slider to insure that the LCD and buttons are working correctly.
- The slider can be moved by rotating the handle [3]. If movement of the slider by hand is required, the gear can be release from the rack by pulling the handle outwards so that it free to slide by hand. When the desired position is achieved the handle can be pushed back in to engage the gear with the rack and the slider moved with the handle.
 NOTE! When using the fine adjustment the gear should be disengaged from the rack and the carriage locking handle [6] loosened.
- Presetting the datum point. Usually the datum or zero point is the surface of the working platform. To set this the following should be done.
 Bring the measuring jaw gently into contact with the working platform surface. (Measuring force 3-5N). The value on the LCD should then be set to "0" by pressing the "ON/Zero" button. Once this has been done then upper and lower presets can be set with the upper and lower preset buttons [15 & 16]

6. BATTERY REPLACEMENT

NOTE! The battery supplied is supplied primary to test the system and may not have a long working life.
 Abnormal display (digits flashing or no display at all) shows a flat battery and it should be replaced. Take off the battery cover [2] in the direction of the arrow shown on the cover and replace the battery with a new SR44W, 1.55V battery. Check the battery's "use by" date to insure that it has not been sitting on the shelf for a long time. (battery's will discharge with long time storage.)
 NOTE! The positive pole [+] must be facing out..
 Replace the battery cover and re-set the zero position.

7. TROUBLE SHOOTING

- Flashing Digits - Possible Cause: low voltage - Solution: Change the battery.
 Frozen Digits - Possible Cause: Accidental Circuit disruption - Solution: Remove battery for two to three minutes and then replace
 No Display - Possible Cause: Low voltage or poor connectors - Solution: Clean the contacts and replace with new battery